



# SPECIFICATION SHEET

Model #:	_____	Qty:	_____
Project #:	_____		
Consultant:	_____		

QUALITY FOOD SERVICE EQUIPMENT

## ECONOMY WORK TABLE



## DIMENSIONS

1-1/2" backsplash

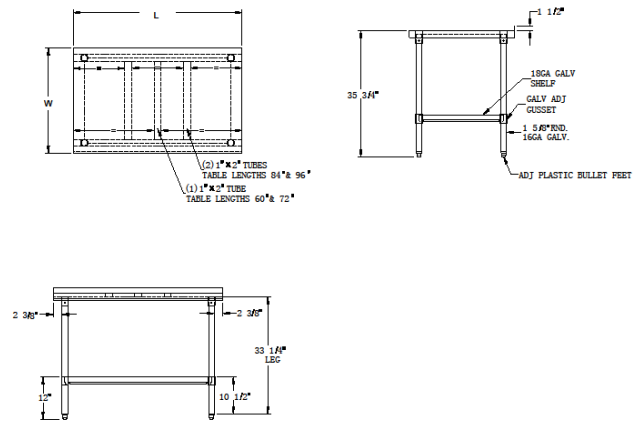

## MATERIAL

- ◆ 18GA 430 stainless steel top
- ◆ Galvanized lower shelf
- ◆ Galvanized legs
- ◆ Plastic bullet feet

Model#	Length	Width
TG-2424R	24"	24"
TG-3024R	30"	24"
TG-3030R	30"	30"
TG-3618R	36"	18"
TG-3624R	36"	24"
TG-3630R	36"	30"
TG-4818R	48"	18"
TG-4824R	48"	24"
TG-4830R	48"	30"
TG-6018R	60"	18"

## FEATURES

- ◆ Straight safety turn down on all sides
- ◆ Adjustable lower shelf
- ◆ Adjustable bullet feet (\*has 6 legs)

Model#	Length	Width
TG-6024R	60"	24"
TG-6030R	60"	30"
TG-7218R	72"	18"
TG-7224R	72"	24"
TG-7230R	72"	30"
TG-8424R*	84"	24"
TG-8430R*	84"	30"
TG-9618R*	96"	18"
TG-9624R*	96"	24"
TG-9630R*	96"	30"

(609) 642-8389 | sales@nbreqquipment.com | www.nbreqquipment.com